

THIS DRAWING IS UNPUBLISHED. RELEASED FOR PUBLICATION
 © COPYRIGHT - By - ALL RIGHTS RESERVED.

LOC	DIST	REVISIONS			
P	LTR	DESCRIPTION	DATE	DWN	APVD
AF	50	Y	REVISED PER ECR-12-013459	28NOV2012	KH PD

1 CONTINUOUS STRIP ON REELS.

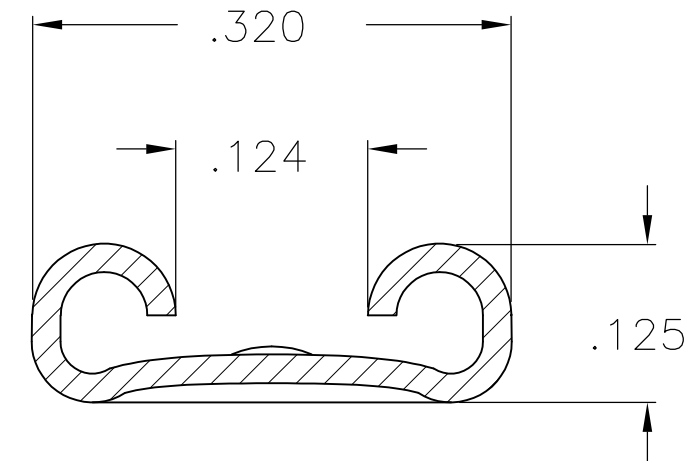
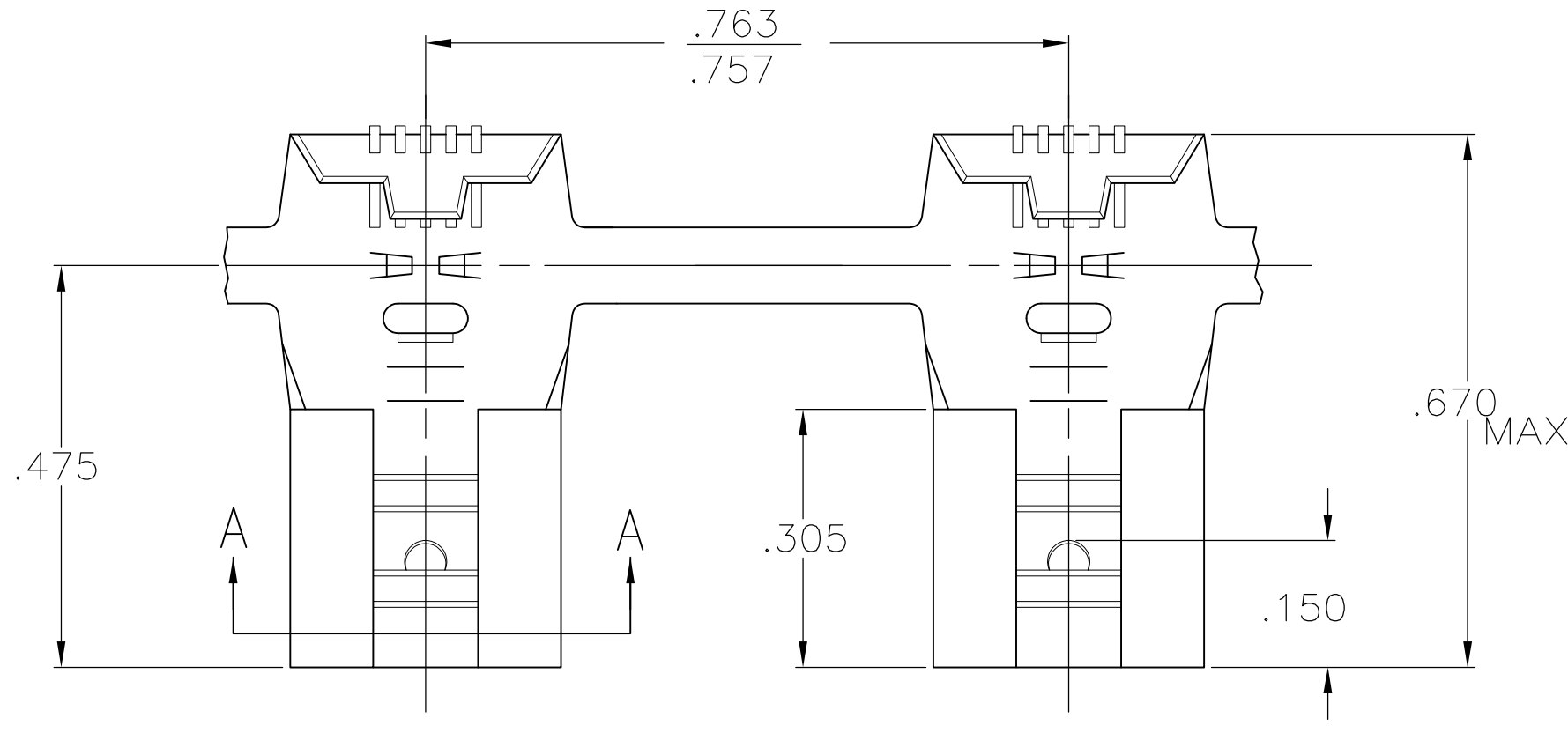

SECTION A-A

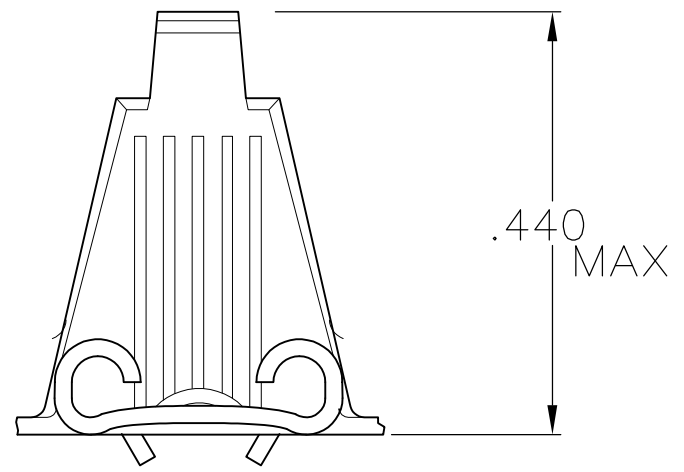

OBSOLETE

REV.	REEL	L.H.	12-10	.032 ±.001	TIN	.018 PHOS. BRONZE	62057-8
			12-10	.032 ±.001	SILVER	.018 PHOS. BRONZE	62057-7
			12-10	.032 ±.001		.018 BRASS	62057-6
			12-10	.032 ±.001	TIN	.018 PHOS. BRONZE	62057-5
			12-10	.032 ±.001	TIN	BRASS	62057-4
			12-10	.032 ±.001	TIN	BRASS	62057-3
			12-10	.032 ±.001	SILVER	.018 PHOS. BRONZE	62057-1
REELING	WIRE SIZE	TAB THK	FINISH	MATERIAL	PART NO.		

THIS DRAWING IS A CONTROLLED DOCUMENT.		DWN JR RUTH 2/3/86	 TE Connectivity				
DIMENSIONS: INCHES		CHK R KUZO 2/7/86					
TOLERANCES UNLESS OTHERWISE SPECIFIED:		APVD C MEYERS 2/7/86	NAME				
0 PLC ± - 1 PLC ± - 2 PLC ± - 3 PLC ± .015 4 PLC ± - ANGLES ± -		PRODUCT SPEC	.250 SERIES FLAG FASTON RECEPTACLE				
MATERIAL SEE TABLE		FINISH SEE TABLE	APPLICATION SPEC	SIZE	CAGE CODE	DRAWING NO	RESTRICTED TO
			WEIGHT	A3	00779	C-62057	
CUSTOMER DRAWING			SCALE	1:1	SHEET	1 OF 1	REV Y